

# ELKAY®

## SPECIFICATIONS

EZH2O® Bottle Filling Station

With Single Filtered Mechanically-Activated Water Cooler

Models LMABF8WS and LMABFDWS

### PRODUCT SPECIFICATION

**RATED FOR INDOOR USE ONLY**

Self-contained, wall hung refrigerated water cooler with bottle filling station. LMABF8WS shall deliver 8 GPH of 50°F drinking water at 90°F ambient and 80°F inlet water. LMABFDWS shall deliver non-chilled drinking water. Unit shall have mechanically-activated pushbar operation. Bottle filling unit shall include an electronic sensor for touchless activation with auto 20-second shut-off timer. Shall include Green Ticker™ displaying count of plastic bottles saved from waste. Bottle filler shall provide 1.1-1.5 gpm flow rate with laminar flow to minimize splashing. Shall include the WaterSentry® Plus 3000-gallon capacity filter, certified to NSF/ANSI 42 and 53, with visual monitor to indicate when replacement is necessary. Shall include integrated silver ion anti-microbial protection in key areas. Unit shall meet ADA guidelines. Unit shall be lead-free design which is certified to NSF/ANSI 61 and 372 and meets Federal and State low-lead requirements. Unit shall be certified to UL399 and CAN/CSA 22.2 No. 120.

### STANDARD FEATURES

- Sanitary, touchless activation with auto 20-second shut-off (Bottle Filler)
- Self-closing, mechanically-activated front and side pushbar controls (Cooler)
- Designed for installations where activation of cooler is needed even during power disruptions
- WaterSentry® Plus 3000-gallon capacity Filtration System, certified to NSF/ANSI 42 & 53 (Lead, Class 1 Particulate, Chlorine, Taste & Odor)
- Integrated Silver Ion Anti-microbial Protection in key areas
- Quick Fill Rate: 1.1 gpm (LMABF8WS); 1.5 gpm (LMABFDWS)
- Laminar Flow provides minimal splash
- Real Drain System eliminates standing water
- Visual User Interface display includes:
  - Innovative Green Ticker™ counts bottles saved from waste
  - LED Visual Filter Monitor shows when replacement is necessary
- Available with Flexi-Guard® Safety Bubbler
- Cooler panel finishes: Light Gray Granite Vinyl Clad Steel or Stainless Steel

### COOLING SYSTEM (Model LMABF8WS only)

- Compressor: hermetically-sealed, reciprocating type, single phase. Sealed-in lifetime lubrication.
- Condenser: Fan cooled, copper tube with aluminum fins. Fan motor is permanently lubricated.
- Cooling Unit: Combination tube-tank type. Self-cleansing. Continuous copper tubing with stainless steel tank. Fully insulated with EPS foam which meets UL requirements for self-extinguishing material.
- Refrigerant Control: Refrigerant R134a is controlled by accurately calibrated capillary tube.
- Temperature Control: Easily accessible enclosed adjustable thermostat is factory preset. Requires no adjustment other than for altitude requirements.

### CAPACITIES CHART

Model	Voltage / Hertz	Chilling** Capacity	F.L. Amps	Rated Watts	Approx. Ship Weight.
LMABF8WS*	115V / 60Hz	8 GPH	4.0	370	75
LMABFDWS*	-	-	1.0	15	40

\*Color code of (L) Light Gray Granite or (S) Stainless Steel cooler panels

\*\*Based on 80°F inlet water & 90°F ambient air temp for 50°F chilled drinking water.

**Warranty:** 5 year limited warranty on the unit's refrigeration system. Electrical components and water system are warranted for 12 months from date of installation or 18 months from factory shipment, whichever date falls first.

In keeping with our policy of continuing product improvement, Elkay reserves the right to change specification without notice. Please visit [elkaypro.com](http://elkaypro.com) for the most current version.

2222 Camden Court  
Oak Brook, IL 60523  
630-572-3192  
[elkay.com](http://elkay.com)



Model LMABF8WSLK or LMABFDWSLKWSLK

### CONSTRUCTION

- Stainless Steel basin with integral drain and embossed bubbler pad
- Galvanized structural steel cooler chassis provides structural integrity
- Cooler cabinet available as Light Gray Granite Vinyl Clad Steel or Stainless Steel (additional cost) construction
- Flexi-Guard® Safety Bubbler utilizes an infused anti-microbial pliable polyester elastomer to prevent accidental mouth injuries. Flexes on impact.

**Replacement Filters:** Available as Singles and Multi-packs. Order part numbers:

- 51300C (single)
- 51300C\_3PK (three)
- 51300C\_12PK (twelve)
- 51300C\_24PK (twenty-four)
- 51300C\_48PK (forty-eight)

### CERTIFICATIONS / STANDARDS

- ADA Compliant
- UL399 and CAN/CSA 22.2 No. 120 Certified
- ANSI/NSF 61 and 372 Certified
- ANSI/NSF 42 and 53 Certified (Filter only)
- GreenSpec® Listed



C USA

This specification describes an Elkay product with design, quality and functional benefits to the user. When making a comparison of other producer's offerings, be certain these features are not overlooked.

**EZH2O® Bottle Filling Station**

With Single Filtered Mechanically-Activated Water Cooler

Models LMABF8WS and LMABFDWS

**ELKAY®**

**ROUGH-IN DIMENSIONS**

**IMPORTANT!**

**INSTALLER PLEASE NOTE**

This water cooler has been designed and built to provide water to the user which has not been altered by materials in the cooler waterways. The grounding of electrical equipment such as telephone, computers, etc., to water lines is a common procedure. This grounding may be in the building but may also occur away from the building. This grounding can cause electrical feedback into a water cooler creating an electrolysis which creates a metallic taste or causes an increase in the metal content of the water. This condition is avoidable by installing the cooler using the proper materials as shown below.

**NOTICE**

This water cooler must be connected to the water supply using a dielectric coupling. The cooler is furnished with a non-metallic strainer which meets this requirement. The drain trap which is provided by the installer should also be plastic to completely isolate the cooler from the building plumbing system.

Bottle Filler unit will mount on bracket attached to wall by 6 holes (as shown). Water and electrical will connect through pre-punched hole in basin.

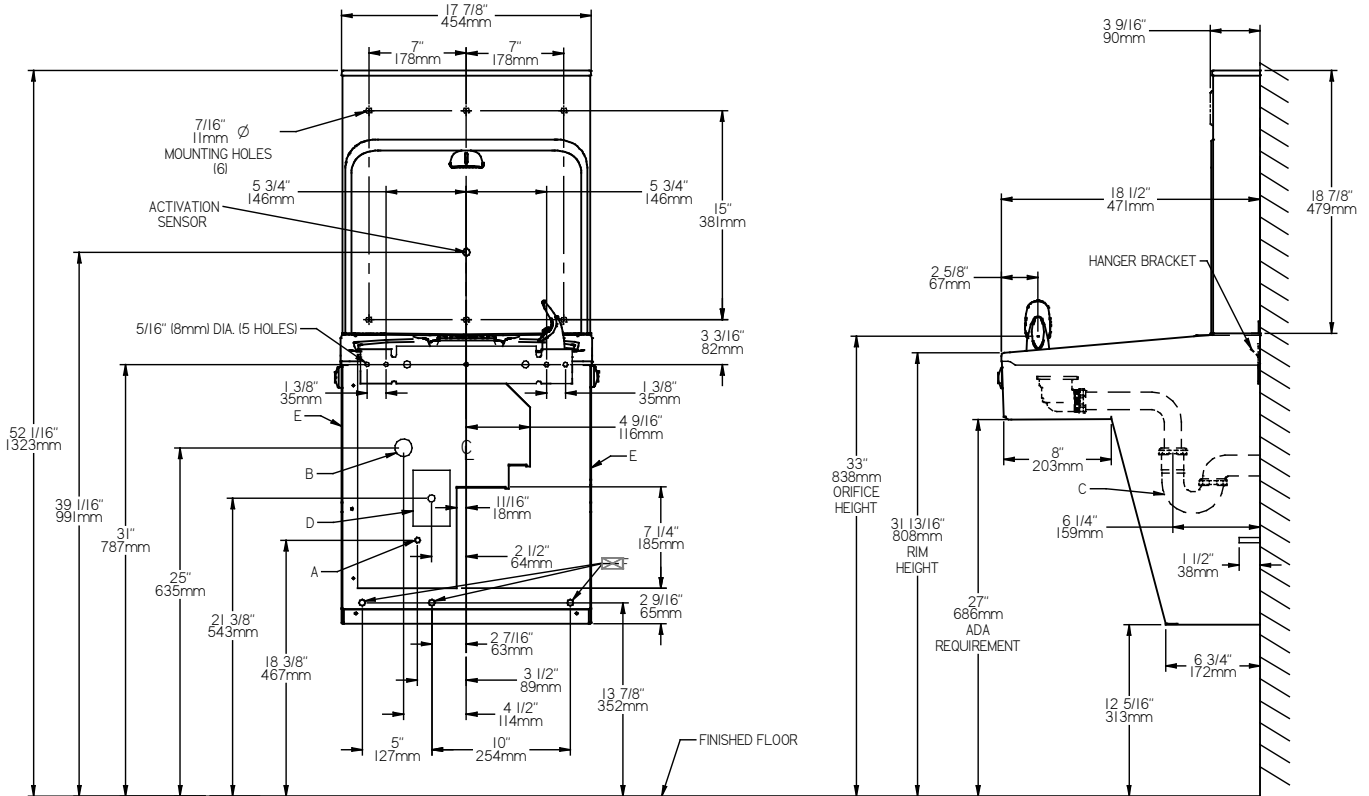

REDUCE HEIGHT BY 3 INCHES FOR INSTALLATION OF CHILDRENS ADA COOLER

**LEGEND:**

- A = Recommended Water Supply location. Shut-off Valve (not furnished) to accept 3/8" O.D. unplated copper tube. Up to 3" (76mm) maximum out from wall.
- B = Recommended Waste Outlet location. To accommodate 1-1/4" nominal drain. Drain stub 2" (51mm) out from wall.
- C = 1-1/4" Trap (not furnished).
- D = Electrical Supply (3) Wire Recessed Box Duplex Outlet.
- E = Insure proper ventilation by maintaining 6" (152mm) minimum clearance from cabinet louvers to wall.
- F = 7/16" (11mm) Bolt Holes for fastening to wall.

\*\*New Installations Must Use Ground Fault Circuit Interrupter (GFCI).

Job Name: _____
Model: _____ Qty. _____
Contact: _____
Approval Signature: _____
Notes: _____