

# FILTER KIT

HWF3000 WaterSentry® Plus Kit  
(Lead, Aesthetic Chlorine Taste & Odor & Particulate Class I Reduction)

**FOR COMMERCIAL USE ONLY**

**IMPORTANT NOTE - To avoid danger of an electric shock hazard, disconnect power to your unit before installing or replacing the filter.**

The Halsey Taylor® WaterSentry® Plus is certified by WQA to NSF/ANSI Standard 42 and 53 for the reduction of Aesthetic Chlorine, Taste and Odor, Particulate Class I, and Lead, as verified and substantiated by test data.



(NOTE: CTO replacement filter is only certified to NSF 42 claims; see WSF6000R Performance Data Sheet for additional information.)

These filter kits are designed to be used with the following Halsey Taylor products.

Halsey Taylor HydroBoost® Bottle Filling Station Models  
Examples include but not limited to: HTHB\*

**NOTICE: Do not use with water that is microbiologically unsafe or of unknown quality without adequate disinfection before or after the system. Filter must be used with filter monitor for 3000 gallon rating**

### General Installation Instructions

1. These filter kits must be installed in compliance with all state and local laws and regulations governing the installation and use of this product. Maximum inlet water temperature 100°F (38°C).
2. Mount filter head in a suitable location, using the filter mounting bracket and screws supplied. Allow enough room under the filter head for installation and removal of filter cartridge (13" minimum).
3. Connect the cold water supply to the filter through a shut-off valve and 3/8" O.D. tubing (supplied by the installer). For ease of servicing, the shut-off valve should be located within easy reach of the filter.

**NOTE: The inlet and outlet fitting supplied as part of the filter head are John Guest Superseal fittings that accept 3/8" O.D. tubing on the filter inlet and 1/4" O.D. tubing on the outlet. They may be used with copper, semirigid nylon or polypropylene tubing, with a rated working pressure equal or greater than encountered in application. Do not use soft or braided tubing.**

4. **CAUTION: If supply pressure will ever exceed 100 psi, install a pressure regulator to limit the inlet pressure to the filter to 100 psi or below. DO NOT ATTACH HOT WATER LINE TO FILTER.**

To make connections on the filter head, loosen locknut. Push the tube end past both o-rings to a positive stop in the filter head recess - approx. 1", locknut may have to be backed out a little more. Screw the locknut hand tight to seal (See Fig. 1). Ends of tubing must be cut square and free of burrs and sharp ends that could cut or nick the o-rings.

5. Connect the outlet of the filter to the inlet of the union using the 1/4" O.D. poly tubing and 1/4" union supplied.
6. Remove filter from carton, remove protective cap, attach filter to filter head by firmly inserting into head and rotating filter clockwise.

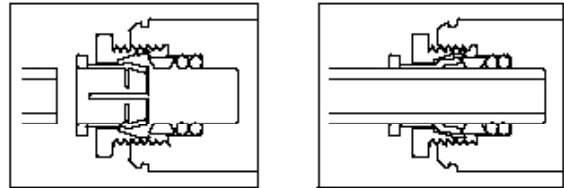


FIG. 1 See Note 4: Screw the locknut hand tight to seal

### OPERATION OF QUICK CONNECT FITTINGS

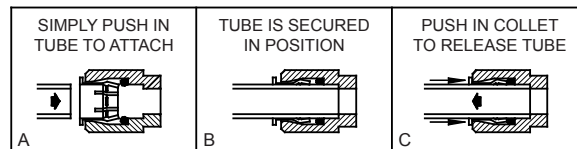


FIG. 2

PUSHING TUBE IN BEFORE PULLING IT OUT HELPS TO RELEASE TUBE

### WaterSentry® Plus In-Wall Bottle Filler and Water Cooler

7a. Turn on water supply and hold open the bubbler on cooler until approximately 1 gallon of water is dispensed. This flushing procedure purges air and fine carbon particles from the filter. When 1 gallon of water has been purged through the cooler, carefully inspect all water connections for leaks.

### WaterSentry® Plus In-Wall Bottle Filler

7b. Turn on water supply and activate the electric eye on In-Wall Bottle Filler until approximately 1 gallon of water is dispensed. Please note that the electric eye activation times out at 30 seconds and will need to be activate repeatedly until one gallon has been passed. This flushing procedure purges air and fine carbon particles from the filter. When 1 gallon of water has been purged through the bottle filler, carefully inspect all water connections for leaks.

### Filter Replacement

1. Turn inlet water valve off.
2. Open bubbler or activate the electric eye to relieve pressure build-up in the system.
3. Remove used filter from head by rotating filter counterclockwise.
4. Remove new filter from carton, remove protective cap; cap may be placed on old filter to reduce the chance of water spilling from filter housing.
5. Attach filter to filter head by firmly inserting into head and rotating filter clockwise.

**NOTE: The filter head contains an automatic shut-off valve that stops the flow of water, if the filter is removed inadvertently without shutting off the incoming water.**

**NOTE: This system and installation shall comply with applicable state and local regulations.**

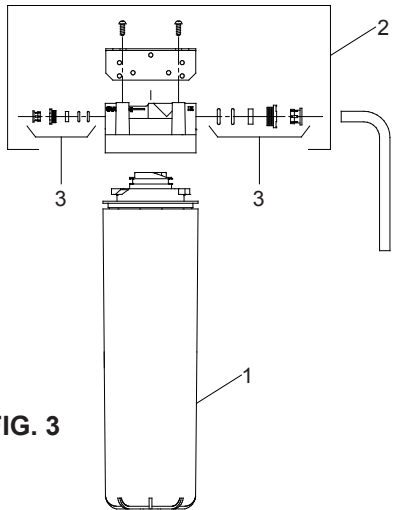
RATED OPERATING CONDITIONS	
Pressure (Max.)	105 PSI (7.4 Kg/cm <sup>2</sup> )
Pressure (Min.)	20 PSI (1.4 Kg/cm <sup>2</sup> )
Flow Rate	1.5 GPM (5.7 LPM)
Rated Capacity	3,000 Gallons (11,358 L)
Temperature (Max.)	100° F (38° C)
Temperature (Min.)	40° F (5° C)

**NOTE:** Performance will vary depending on local water conditions.

**Table A**

REPLACEMENT FILTER		
Filter	Part No.	Description
Halsey Taylor® WaterSentry® Plus	55898C	Lead Reduction , C.T.O. Filter
WaterSentry® Fresh	WSF6000R	CTO (replacement only)

Item No.	Part No.	Description
1	See Table	Filter Assembly
*2	98926C	Kit - Filter Head Fitting Includes John Guest Ftgs
**3	1000003563	Assy - Filter & Bracket Includes Filter Head/ Mtg Bracket/John Guest Ftgs/Screws

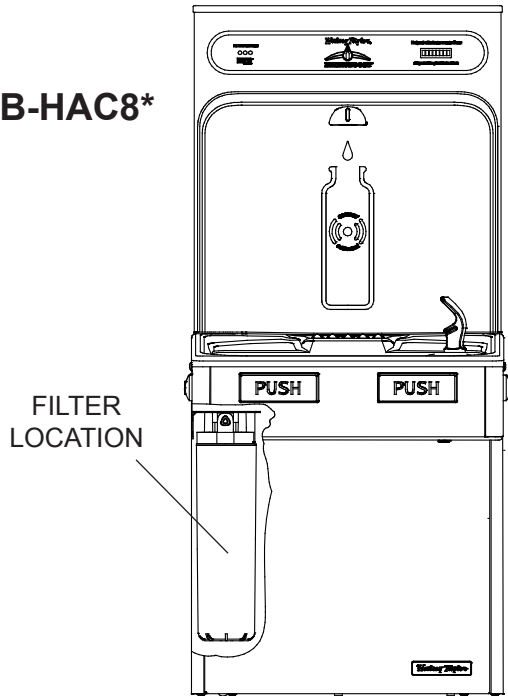


**FIG. 3**

**\*Note:** Bracket can be turned over to provide better fit in some models.

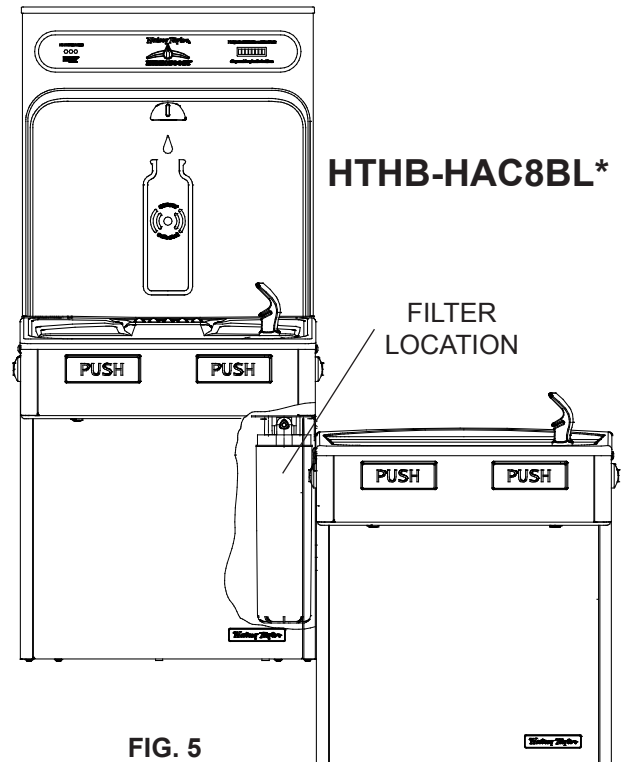
**\*\*Item No. 3** includes Filter Head, Bracket, Screws, Superseal Fittings, and 3/8" copper Inlet Tube.

**HTHB-HAC8\***

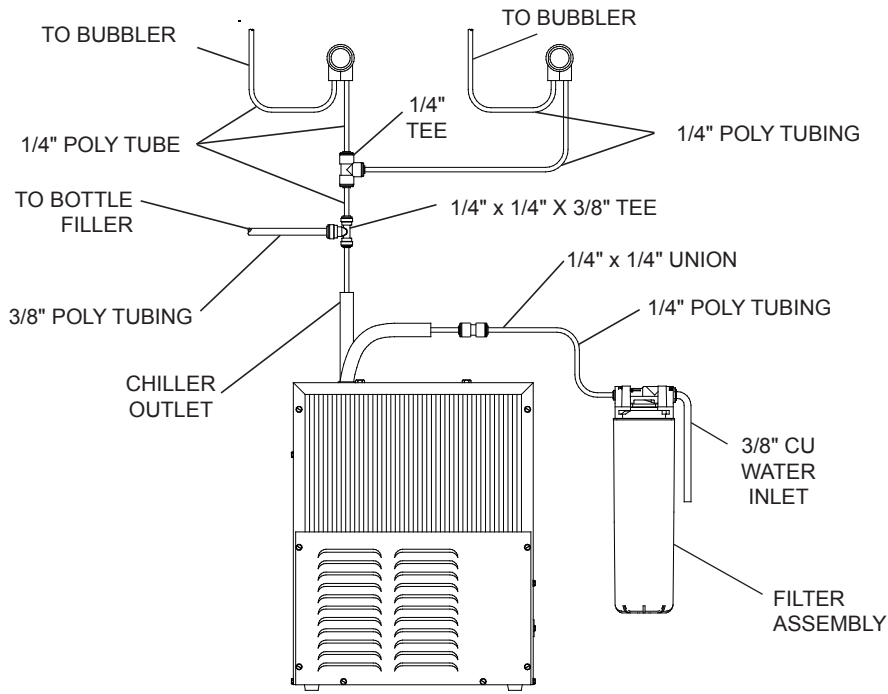


**FIG. 4**

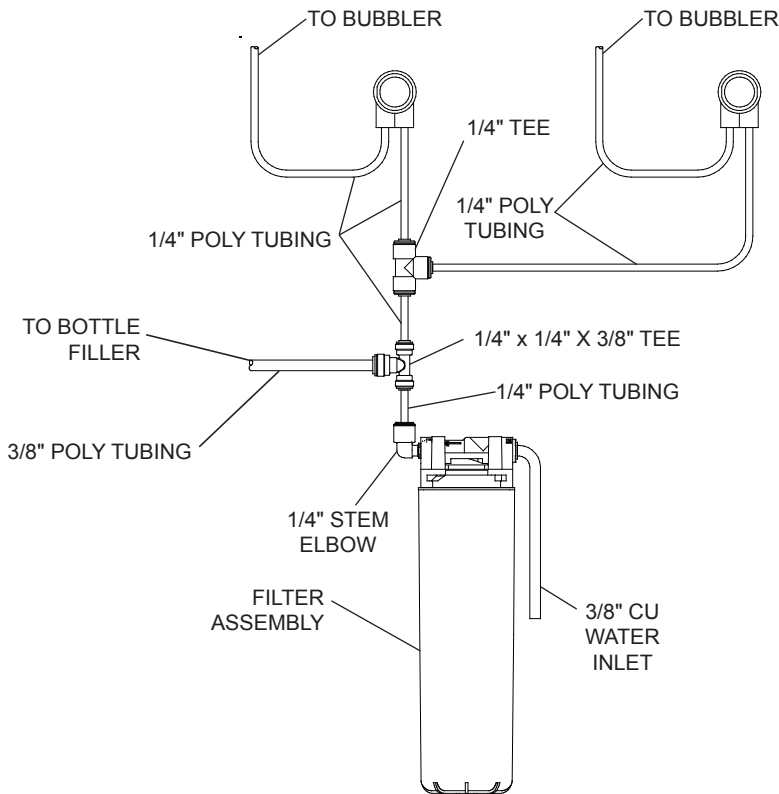
**HTHB-HAC8BL\***



**FIG. 5**



INSTALLATION WHEN USED WITH WATER CHILLER **FIG.6**



PLUMB FILTER OUTLET DIRECTLY TO IN-WALL BOTTLE FILLER IF NO CHILLER IS USED **FIG.7**

See page 4 for replacement information.

**NOTICE**

To receive maximum benefit from your Halsey Taylor® WaterSentry® filters, note the installation dates below and change according to the following guidelines.

**REPLACEMENT FILTER OPTIONS**

**HALSEY TAYLOR® Part No. 55898C WaterSentry® Plus — Lead Reduction Filter**

Change every 3,000 gallons as indicated by the filter monitor, or once a year – whichever occurs first.

OR

**Part No. WSF6000R WaterSentry® Fresh — CTO Filter**

Change every 6,000 gallons as indicated by the filter monitor, or once a year – whichever occurs first.

**– KEEP THIS SHEET IN A HANDY LOCATION –**

DATE INSTALLED	MODEL (TYPE OF FILTER)	SERVICE PERSON	DATE INSTALLED	MODEL (TYPE OF FILTER)	SERVICE PERSON

**Halsey Taylor®**  
 2222 CAMDEN COURT  
 OAK BROOK, IL 60523  
 630.574.3500

FOR PARTS, CONTACT YOUR LOCAL DISTRIBUTOR OR VISIT OUR WEBSITE WWW.HALSEYTAYLOR.COM