

ELKAY®

SPECIFICATIONS

EZH2O® Bottle Filling Station Filtered In-Wall (for use with EDFPB SwirFlo® fountains) Models LZWS8K, LZWSM8(2-3)K and LZWSMD(JO)K

PRODUCT SPECIFICATION

RATED FOR INDOOR USE ONLY

In-wall recessed bottle filling station for use with EDFPB SwirFlo® fountains. Models LZWS(M)8(2-3)K shall deliver 8 GPH of 50°F drinking water at 90°F ambient and 80°F inlet water. Models LZWSMD(JO)K shall deliver non-chilled drinking water. Units shall be stainless steel construction with plastic ABS alcove. Sensor-activation with an auto 20-second shut-off timer. Shall include Green Ticker™ displaying count of plastic bottles saved from waste. Bottle filler shall provide 1.1-1.5 gpm flow rate with laminar flow to minimize splashing. Shall include the WaterSentry® Plus 3000-gallon capacity filtration system, certified to NSF/ANSI 42 and 53, with visual monitor to indicate when replacement is necessary. Shall include integrated silver ion anti-microbial protection in key areas. Unit shall meet ADA guidelines. Unit shall be lead free design which is certified to NSF/ANSI 61 and 372 and meets Federal and State low-lead requirements. Unit shall be certified to UL399 and CAN/CSA 22.2 No. 120.

- Models LZWSM8K, LZWSM82K, LZWSM83K, LZWSMDK, LZWSMDJOK – Mounting frame MFWS100 is included.
- Model LZWS8K – Used when mounting frame is pre-ordered for early installation



STANDARD FEATURES

- Special panel height designed to pair with non-refrigerated EDFPB SwirFlo® models
- Sanitary, touchless activation with auto 20-second shut-off (Bottle Filler)
- WaterSentry® Plus 3000-gallon capacity Filtration System, certified to NSF/ANSI 42 & 53 (Lead, Class 1 Particulate, Chlorine, Taste & Odor)
- Integrated Silver Ion Anti-Microbial Protection in key areas
- Quick Fill Rate: 1.1 gpm (LZWS(M)8(2-3)K); 1.5 gpm (LZWSMD(JO)K)
- Laminar Flow provides minimal splash
- Real Drain System eliminates standing water
- Visual User Interface display includes:
 - Innovative Green Ticker™ counts bottles saved from waste
 - LED Visual Filter Monitor shows when replacement is necessary
- Includes lower hinged panel for easy access and servicing

COOLING SYSTEM (Models LZWS(M)8(2-3)K)

- High-efficiency compressor: hermetically-sealed, reciprocating type, single phase. Sealed-in lifetime lubrication.
- Condenser: Fan cooled. Fan motor is permanently lubricated.
- Cooling Unit: Combination tube-tank type. Continuous copper tubing with stainless steel tank. Fully insulated with EPS foam which meets UL requirements for self-extinguishing material.
- Refrigerant Control: Refrigerant R134a is controlled by accurately calibrated capillary tube.
- Temperature Control: Enclosed adjustable thermostat is factory preset. Requires no adjustment other than for altitude requirements, Easily accessible by removing lower grille panel.

Warranty: 5 year limited warranty on the unit's refrigeration system. Electrical components and water system are warranted for 12 months from date of installation or 18 months from factory shipment, whichever date falls first.



Models LZWS8K, LZWSM8K, LZWSM82K, LZWSM83K







Models LZWSMDK, LZWSMDJOK

CONSTRUCTION

- Stainless steel bottle filler construction with ABS plastic alcove
- Includes stainless steel lower panel. LZWS(M)8(2-3)K models have louvered ventilating grille; LZWSMD(JO)K models have solid panel.
- Furnished with MFWS100 wall mounting box constructed of galvanized steel. Mounting can be ordered separately for pre-install.
- Models LZWSM8K, LZWSM82K, LZWSM83K, LZWSMDK, LZWSMDJOK include MFWS100 wall mounting frame constructed of galvanized steel.
- Model LZWS8K, mounting frame MFWS100 can be ordered separately for pre-install.

REPLACEMENT FILTERS: Available as Singles and Multi-packs.

- 51300C (single)
- 51300C_3PK (three)
- 51300C_12PK (twelve)
- 51300C_24PK (twenty-four)
- 51300C_48PK (forty-eight)

CAPACITIES CHART									
Model	Voltage / Hertz	Chilling** Capacity	F.L. Amps	Rated Watts	Approx. Ship Wt.	ADA Compliant	UL399 and CAN/CSA 22.2 No. 120 Certified	NSF/ANSI 61 and 372 Certified 42 and 53 Certified (filter only)	GreenSpec® Listed
LZWS(M)8K	115V / 60Hz	8.0 GPH	5.0	370	80 lbs.	•	•	•	•
LZWSM82K	220V / 50Hz	6.7 GPH	2.0	370	80 lbs.	•	•	•	•
LZWSM83K	220V / 60Hz	8.0 GPH	2.2	370	80 lbs.	•	•	•	•
LZWSMDK	115V / 60Hz	-	1.0	15	33 lbs.	•	•	•	•
LZWSMDJOK	220V / 50-60Hz	-	1.0	15	33 lbs.	•	•	•	•

**Based on 80°F inlet water & 90°F ambient air temp for 50°F chilled drinking water.

This specification describes an Elkay product with design, quality and functional benefits to the user. When making a comparison of other producer's offerings, be certain these features are not overlooked.

EZH20® Bottle Filling Station

Filtered In-Wall (for use with EDFPB SwirFlo® fountains)

Models LZWS8K, LZWSM8(2-3)K and LZWSMD(JO)K

ELKAY®
ROUGH-IN DIMENSIONS

RATED FOR INDOOR USE ONLY

Job Name: _____
 Model: _____ Qty. _____
 Contact: _____
 Approval Signature: _____
 Notes: _____

MOUNTING FRAME FOR MODEL LZWSMD(JO)K

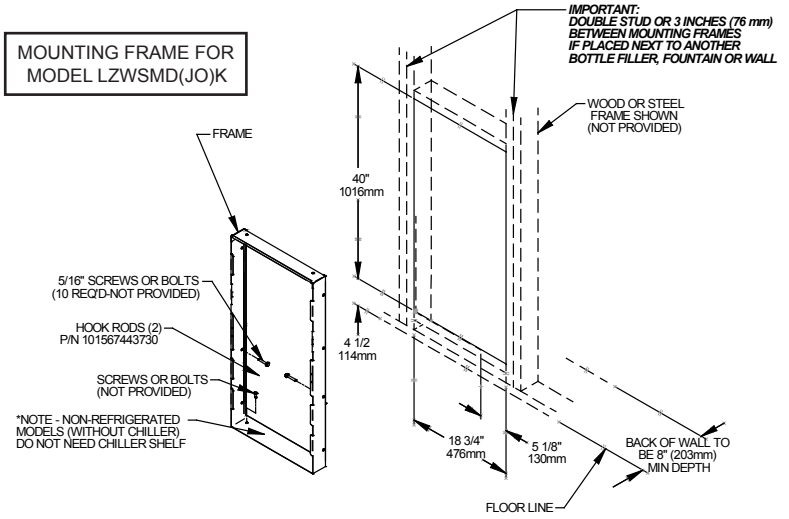

MOUNTING FRAME FOR MODEL LZWS(M)8(2-3)K

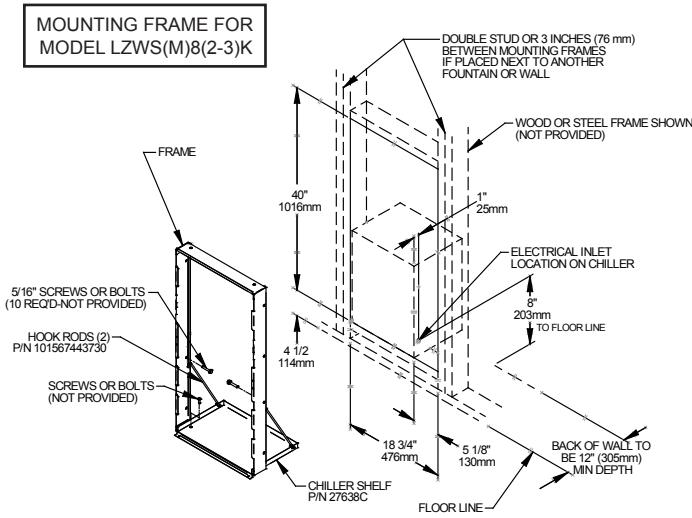

TOP & SIDE VIEWS

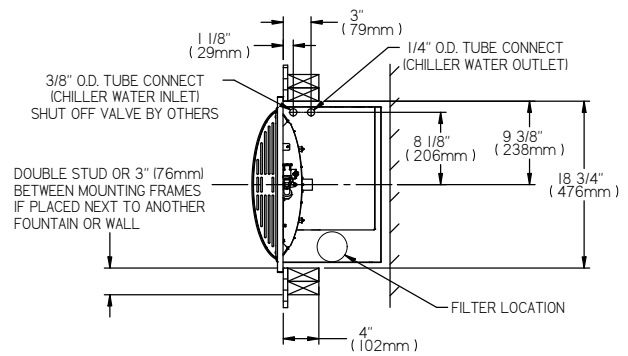

FRONT VIEW

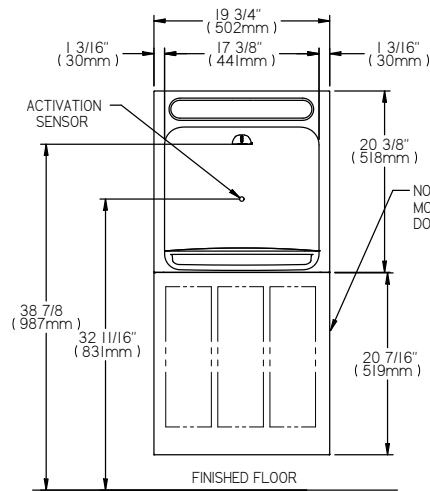

WALL LAYOUT

