

ELKAY[®]

SPECIFICATIONS

MODEL LK4420BF1UDB and MODEL LK4420BF1LDB

GENERAL

Steel Outdoor Dual Station Fountain with Pet Fountain and Bottle Filling Station with rounded corner design, heavy-duty steel with textured powder-coat finish and E-Coat immersion for year-round beauty with minimum maintenance. The E-Coat immersion process coats the inside and outside for the ultimate in corrosion protection.

BOTTLE FILLER

Provides a quick fill at 1 gallon per minute. Laminar flow provides a clean fill with minimal splash and easy maintenance.

BUBBLER

Vandal-resistant bubbler is one-piece, heavy-duty construction. Unit has integral hood guard design to prevent contamination from other users, airborne deposits and tampering.

BASIN

Contour-formed stainless steel design with rounded edges reduces splatter, ensures proper drainage and prevents standing water.

PUSHBUTTON ACTUATION MECHANISM

Self-closing, vandal-resistant pushbutton does not require grasping or twisting.

INLET STRAINER

Easily cleaned in-line strainer screen traps particles of 140 microns or larger before they enter the waterway.

WATER INLET & DRAIN OUTLET

Inlet: 3/8" O.D. Tubing

Outlet: 1-1/2" tube outlet for 1-1/2" slip joint connection

ACCESS PANELS



Heavy-gauge steel with vandal-resistant screws. Provides access for easy hook-up of all plumbing connections.

PET FOUNTAIN

Actuated by upper pushbutton. Slow drainage feature for easy drinking.

SUGGESTED SPECIFICATIONS

Unit shall include powder-coated finish with vandal-resistant pushbutton actuation, vandal-resistant bubblers with integral hood guard, and contour-formed rounded basins to reduce splash and prevent standing water. Bottle Filler shall include a laminar flow for minimal splash and provide 1 gallon per minute fill rate. Fountain shall comply with ANSI 117:1 and ADA for visual and motion disabilities. The manufacturer shall certify the unit to meet the requirements of NSF/ANSI 61, and the Safe Drinking Water Act.

Model	Bottle Filler Placement	Color Option		
			ADA Compliant	NSF/ANSI 61 Certified
LK4420BF1UDB*	Upper	(Refer to Finish Color Options)	•	•
LK4420BF1LDB*	Lower	(Refer to Finish Color Options)	•	•

* Select color option to complete model number. Example: LK4420BF1UDBEVG

This specification describes an Elkay product with design, quality and functional benefits to the user. When making a comparison of other producer's offerings, be certain these features are not overlooked.

In keeping with our policy of continuing product improvement, Elkay reserves the right to change specification without notice. Please visit elkay.com for the most current version.

2222 Camden Court
Oak Brook, IL 60523
630-572-3192
elkay.com

Outdoor Tubular Bottle Filling Station

Dual Station with Pet Fountain



Now Available
in 12 Colors!



FINISH COLOR OPTIONS – Choose color option to complete your model number, add as suffix example:
LK4420BF1UDBEVG

Matte finish: Evergreen = EVG

Gloss finish:

- | | | |
|--------------------------------------|---------------------------------------|---|
| <input type="checkbox"/> Beige = BGE | <input type="checkbox"/> Gray = GRY | <input type="checkbox"/> Terracotta = TER |
| <input type="checkbox"/> Black = BLK | <input type="checkbox"/> Orange = ORN | <input type="checkbox"/> White = WHT |
| <input type="checkbox"/> Blue = BLU | <input type="checkbox"/> Purple = PUR | <input type="checkbox"/> Yellow = YLW |
| <input type="checkbox"/> Brown = BRN | <input type="checkbox"/> Red = RED | |

OPTIONS

- Hose Bib (Locking) - LK4471LHB* (Choose color option to complete your model number)
- Hose Bib (Non-Locking) - LK4470NLHB* (Choose color option to complete your model number)
- Direct Bury Kit - 97890C

MODEL LK4420BF1UDB

Outdoor Tubular Bottle Filling Station

OPERATING PRESSURES:
Supply water 20 – 105 psi maximum

TOP VIEW

MOUNTING INSTRUCTIONS and PLUMBING CONNECTIONS

Provide solid, well-drained surface to mount pedestal fountain (concrete pad recommended). Mount on a smooth, flat, finished surface with adequate support (300 lb. load minimum). Secure unit with (8) 3/8" minimum fasteners (not included). Refer to rough-in. Should be attached firmly to mounting surface in order to secure unit.

Modified low stream height bubbler for pet fountain.

Locate and install plumbing through ground as required.

NOTE: Unit is not furnished with service valve.

Position pedestal over plumbing and secure base to fasteners. Remove access panels and connect supply and water lines. Turn on water supply and check for leaks. Reassemble access panels to pedestal.

Trap and service stop not included.

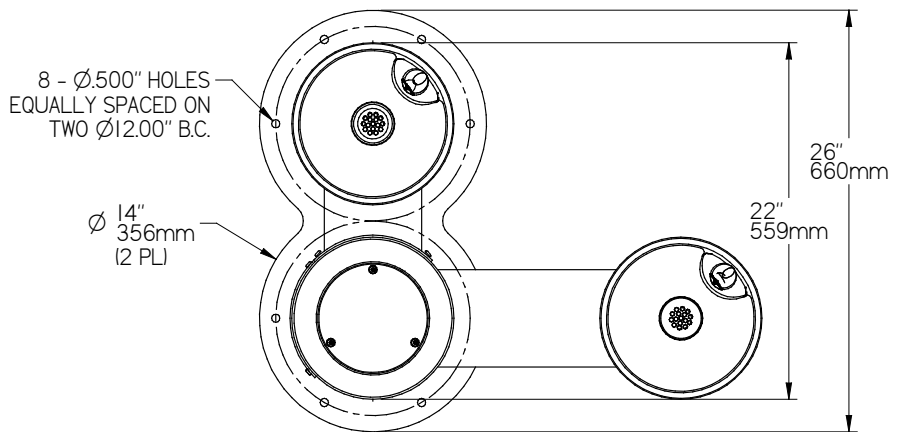

FRONT & SIDE VIEWS

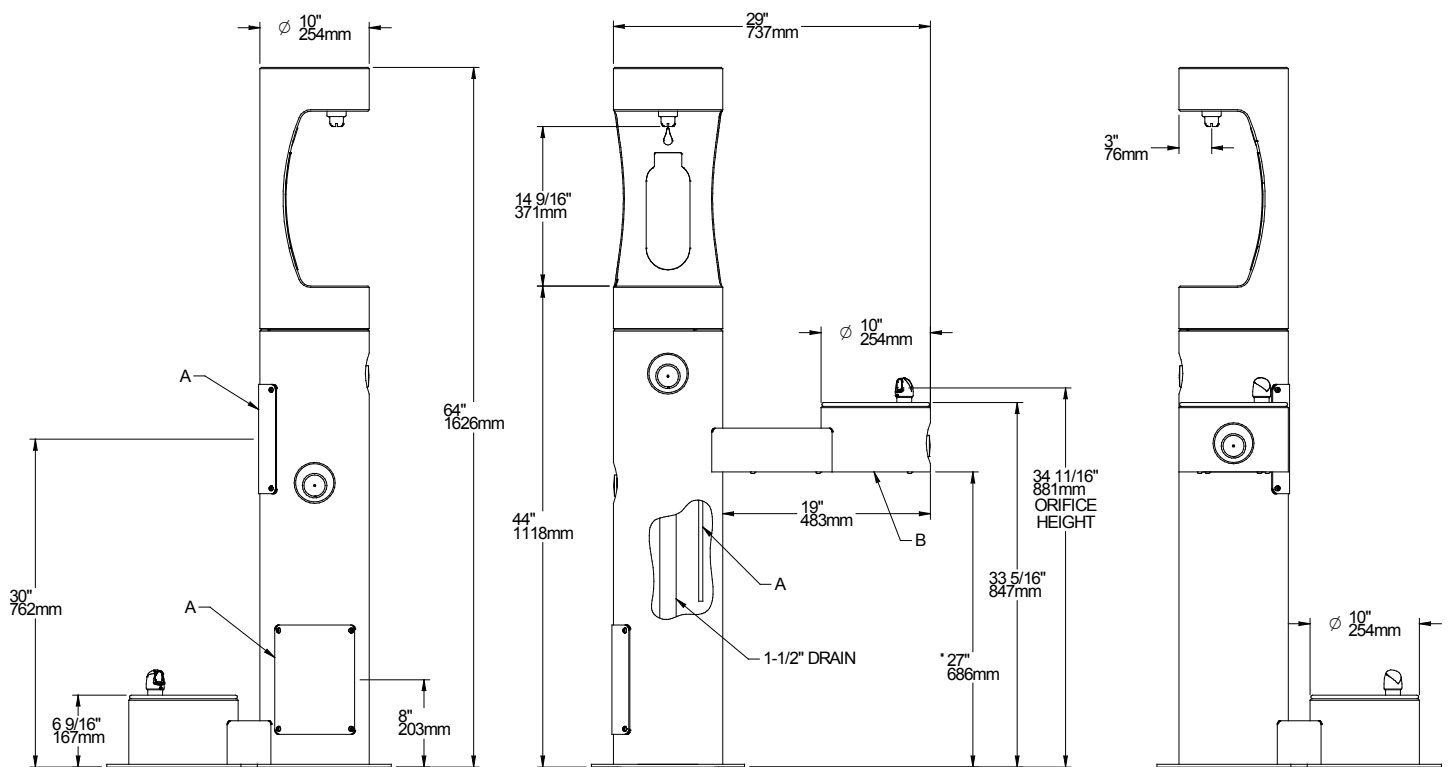

A = 3/8" O.D. UNPLATED COPPER TUBE CONNECT SHUT OFF VALVE BY OTHERS
 B = ACCESS PANEL (8" x 10")
 C = REMOVABLE BOTTOM COVER

MODEL LK4420BF1LDB

Outdoor Tubular Bottle Filling Station

OPERATING PRESSURES:
Supply water 20 – 105 psi maximum

TOP VIEW

MOUNTING INSTRUCTIONS and PLUMBING CONNECTIONS

Provide solid, well-drained surface to mount pedestal fountain (concrete pad recommended). Mount on a smooth, flat, finished surface with adequate support (300 lb. load minimum). Secure unit with (8) 3/8" minimum fasteners (not included). Refer to rough-in. Should be attached firmly to mounting surface in order to secure unit.

Modified low stream height bubbler for pet fountain.

Locate and install plumbing through ground as required.

NOTE: Unit is not furnished with service valve.

Position pedestal over plumbing and secure base to fasteners. Remove access panels and connect supply and water lines. Turn on water supply and check for leaks. Reassemble access panels to pedestal.

Trap and service stop not included.

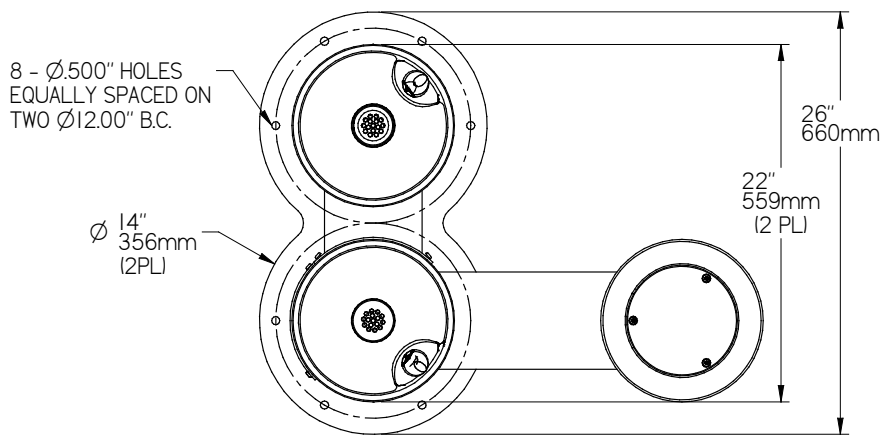

FRONT & SIDE VIEWS

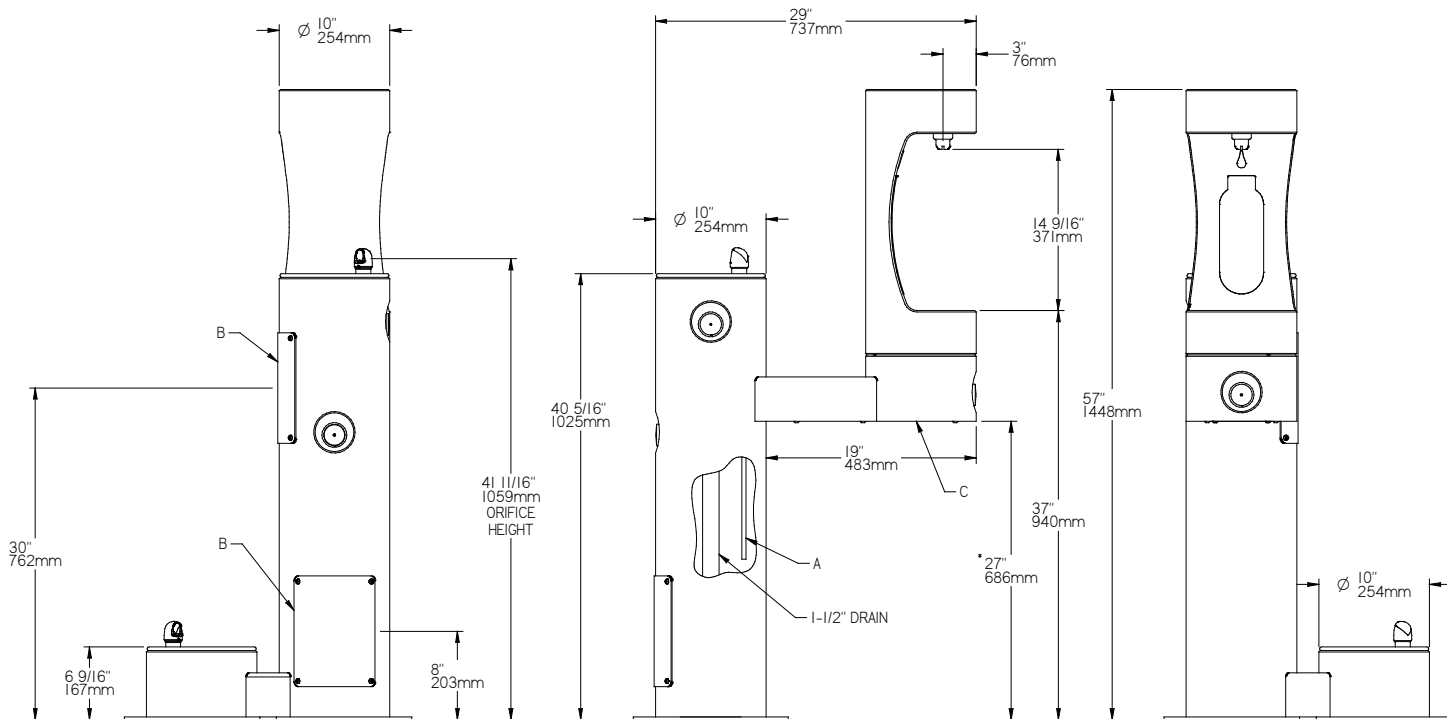

* ADA Requirement

- A = 3/8" O.D. UNPLATED COPPER TUBE CONNECT SHUT OFF VALVE BY OTHERS
- B = ACCESS PANEL (8" x 10")
- C = REMOVABLE BOTTOM COVER