

ELKAY®

SPECIFICATIONS

EZH2O® In Wall Bottle Filling Station Retro-fit Model for Soft Sides® Refrigerated Fountain Model EZWS-ERFP8-RF

RATED FOR INDOOR USE ONLY

PRODUCT SPECIFICATION

In-wall EZWS-ERFP8-RF Retro-fit system will update existing refrigerated Bi-Level Soft Sides® installations with an integrated Bottle Filler system. Units shall be stainless steel construction with plastic ABS alcove. Sensor activation with an auto 20-second shut-off timer. Shall include GreenTicker™ displaying count of plastic bottles saved from waste. Bottle filler shall provide 1.1 gpm flow rate with laminar flow to minimize splashing. Shall include integrated silver ion anti-microbial protection in key areas. Bottle filler meets ADA guidelines for reach range; fountain meets ADA guidelines for wheelchair access. Unit shall be lead-free design which is certified to NSF/ANSI 61 and 372 and meets Federal and State low-lead requirements. Unit shall be certified to UL399 and CAN/CSA 22.2 No. 120.

STANDARD FEATURES

Bottle Filler

- No-touch, sensor-activated operation.
- Auto 20-second shut-off.
- Integrated Silver Ion Anti-microbial Protection in key areas.
- Quick Fill Rate: 1.1 gpm.
- Laminar Flow provides minimal splash.
- Real Drain System eliminates standing water.
- Visual User Interface display includes:
 - Innovative Green Ticker™ counts bottles saved from waste.

FOUNTAINS / COOLING SYSTEM

One fountain, one mounting frame (for lower fountain installation) and the cooling system are reused from the current existing installation.

CAPACITIES CHART

| Model | Voltage / Hertz | Chilling Capacity | F.L. Amps | Rated Watts | Approx. Ship Weight. |
|---------------|-----------------|---------------------------------|-----------|-------------|----------------------|
| EZWS-ERFP8-RF | 115V / 60Hz | Based on Existing Cooler Rating | 1.0 | 15 | 50 |

The above ratings apply only to the EZWS-ERFP8-RF unit. Ratings for cooler not included.

Model
EZWS-ERFP8-RF



CONSTRUCTION

- Stainless steel bottle filler construction with ABS plastic alcove.
- Includes ventilating louvered grille with fountain.
- Furnished with open wall frame mounting box constructed of galvanized steel.

Each EZWS-ERFP8-RF is shipped in one carton containing:

- Upper panel with installed bottle filler
- Lower panel with ventilation louvers
- Mounting frame for bottle filler
- Misc. hardware

Warranty: Electrical components and water system are warranted for 12 months from date of installation or 18 months from factory shipment, whichever date falls first.

CERTIFICATIONS / STANDARDS

- ADA Compliant
- UL399 and CAN/CSA 22.2 No. 120 Certified
- ANSI/NSF 61 and 372 Certified
- GreenSpec® Listed



This specification describes an Elkay product with design, quality and functional benefits to the user. When making a comparison of other producer's offerings, be certain these features are not overlooked.

**EZH20® In Wall Bottle Filling Station Retro-fit Model
for Soft Sides® Refrigerated Fountain
Model EZWS-ERFP8-RF**

**ELKAY®
ROUGH-IN**

Job Name: _____
 Date: _____ Qty. _____
 Contact Info (Name, Phone, Email): _____

 Approval: _____

IMPORTANT!

**Rated for indoor use only*

EZWS-ERFP8-RF Retro-fit is designed to fit on an existing Soft Sides® refrigerated style fountain which is properly installed per the Spec Sheet rough-in information.

ELECTRICAL

EZWS-ERFP8-RF equipped with electrical cord and three-prong molded rubber plug for use with 15-amp minimum receptacle. Rated at 115V/60Hz, single phase.

INSTALLATION STEPS

Disassemble current Bi-Level Refrigerated fountain installation

Remove left hand mounting frame, replace with new open frame (included)

Reassemble installation with new upper panel / Bottle Filler assembly, original fountain, original lower mounting frame, chiller shelf, chiller unit and new lower panel assembly

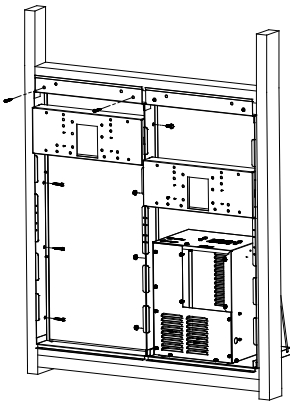

Typical current installation with fountains and panels removed

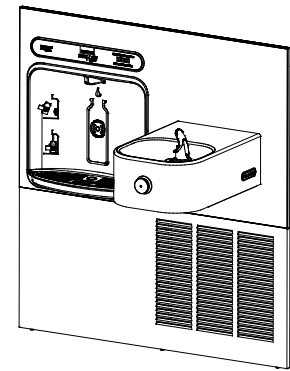
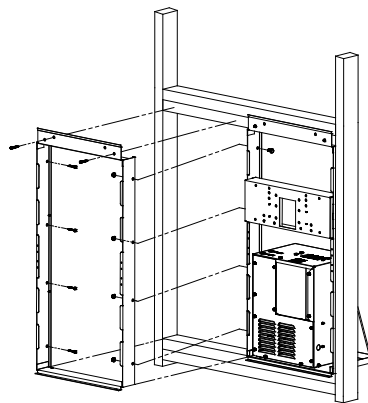

BOTTLE FILLER / FOUNTAIN INSTALLATION AFTER RETRO-FIT CONVERSION

